

FOCO ROOM DIVIDER 1200

BIO-30-112

O Foco Room Divider 1200 é uma elegante lareira de bioetanol embutida, projetada para instalação em paredes divisórias, permitindo apreciar as chamas de três lados. Este modelo de 120 cm de largura pode ser equipado com um queimador de bioetanol manual ou automático, oferecendo várias opções de controlo. Fabricado em aço inoxidável revestido a pó e equipado com vidro temperado, que garante uma chama estável e bonita, adicionando uma atmosfera elegante a qualquer espaço. A instalação é simples e não requer nenhuma certificação especial.

TECHNICAL SPECIFICATIONS

Brændkammer

Requer electricidade	Não
Requer electricidade	Sim
Ajustável	Sim
Controlo	Controlo remoto
Controlo	Automático
Controlo	Manual
Tempo de combustão	6 horas
Tamanho mínimo do quarto	90 m ³
Queimadores	5 Litros Superior
Comprimento da chama	85 cm
Potência de calor (máx)	6,2 kW
Consumo	0,87 l/h
Controlo Remoto	Sim (compra adicional)

Størrelse

	50
Comprimento/Largura	120 cm
Peso	30 kg
Profundidade	40 cm

Udseende

Espessura do aço	4 mm
Material	Aço
Cor	Preto
Vidro incluído	Sim

Type

Montagem	Lareira a bioetanol embutida de 3 lados
Combustível	Bioetanol
Chaminé	Não é requerida
Taxa de mudança de ar recomendada	1
Garantia	2 anos
Uso	Interior
Vista da chama	Divisória de espaços
Fabricante	Foco

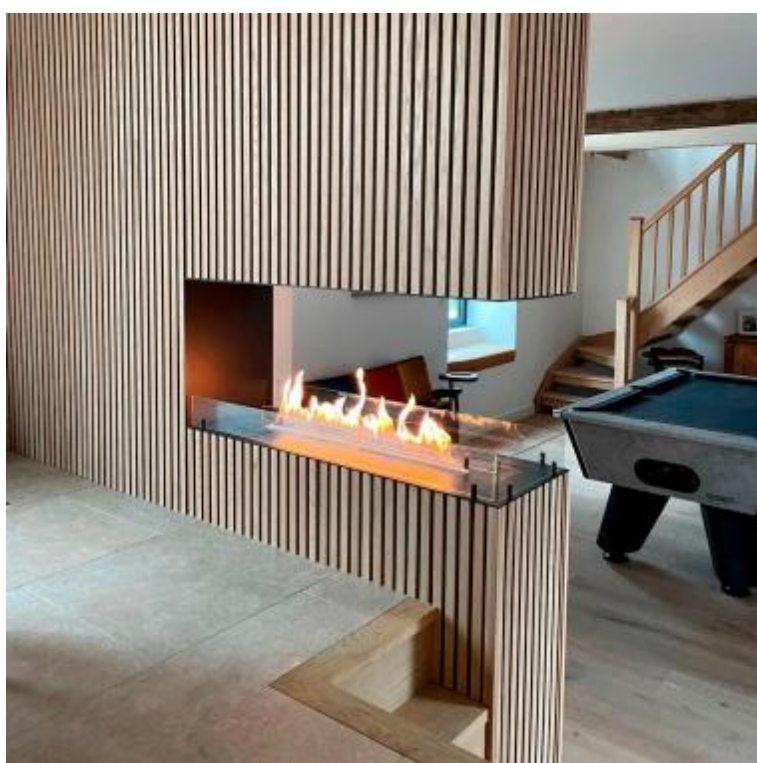

PrimeFire 1000

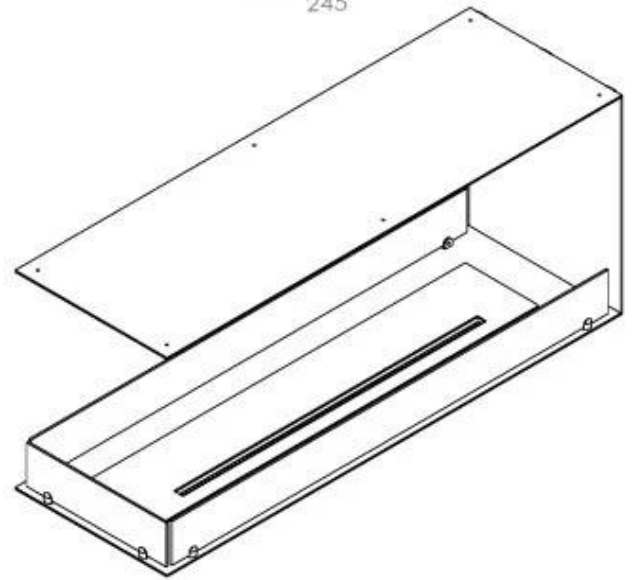
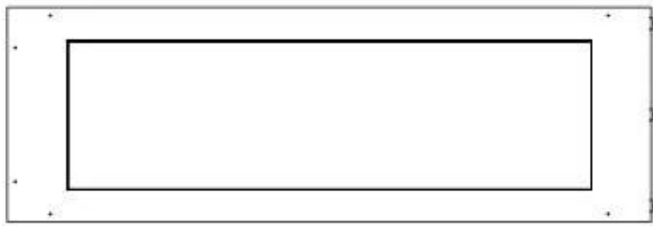
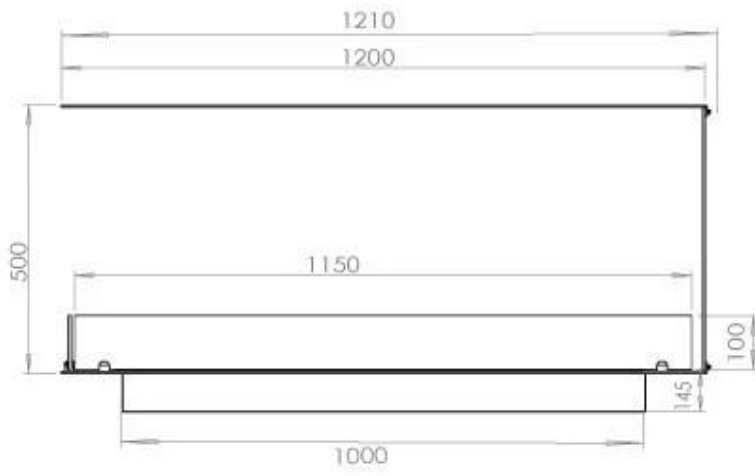

FLA 3 990 mm

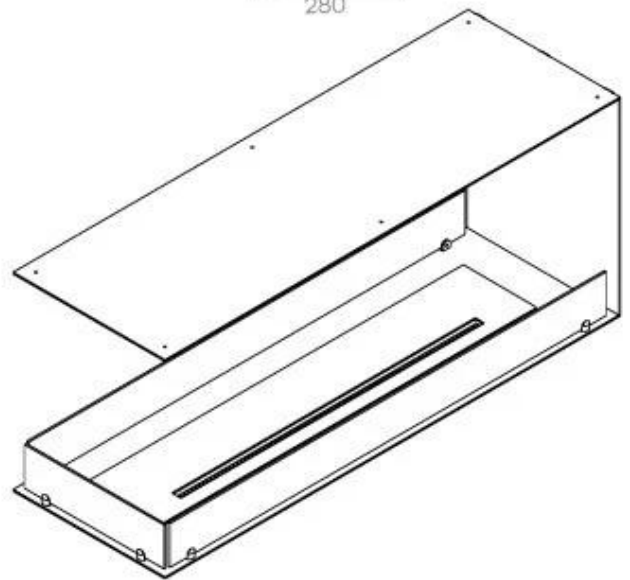
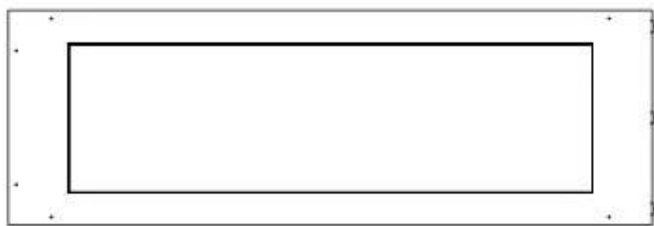
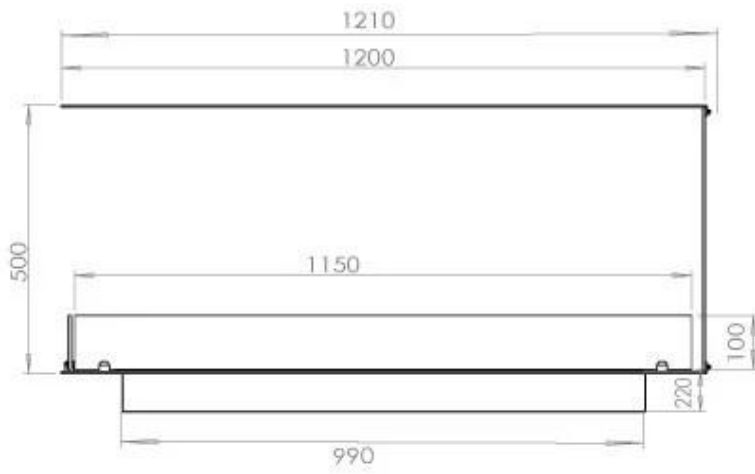

FLA 3+ 990 mm

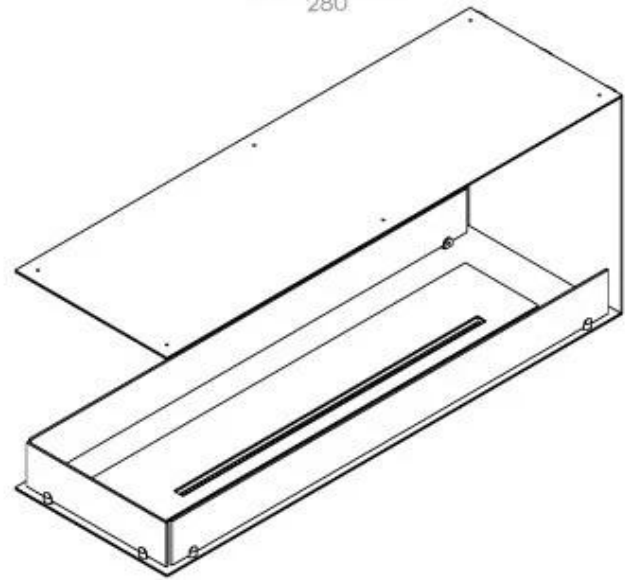
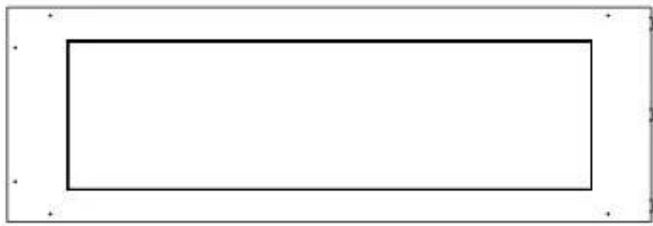
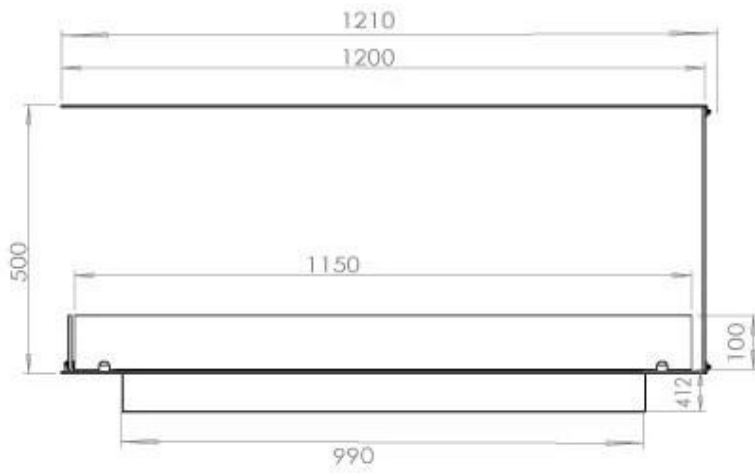

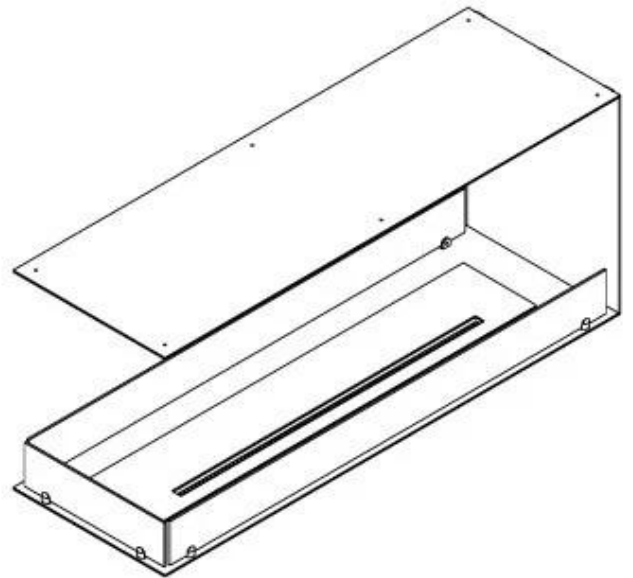
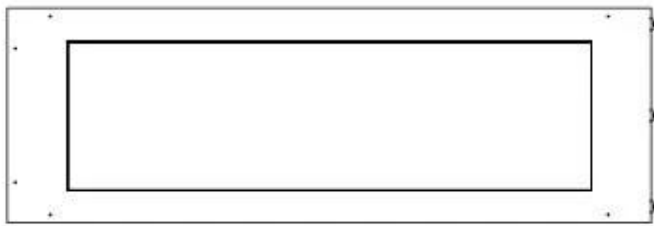
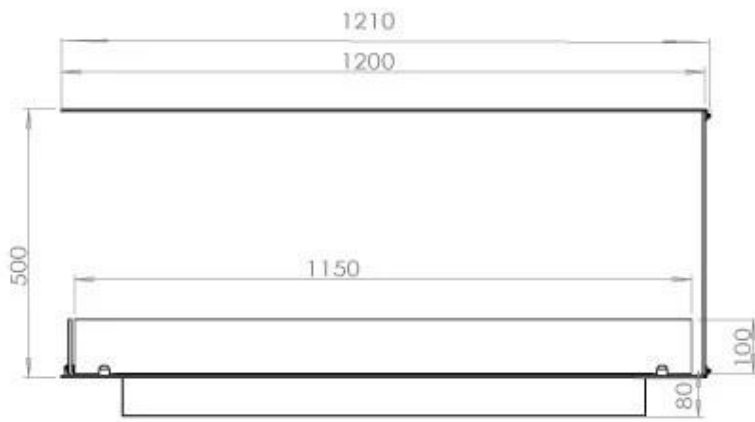

Automatic burner 1000

